

---

# Electric Circuits

---

AP Physics C

# Potential Difference = Voltage = EMF

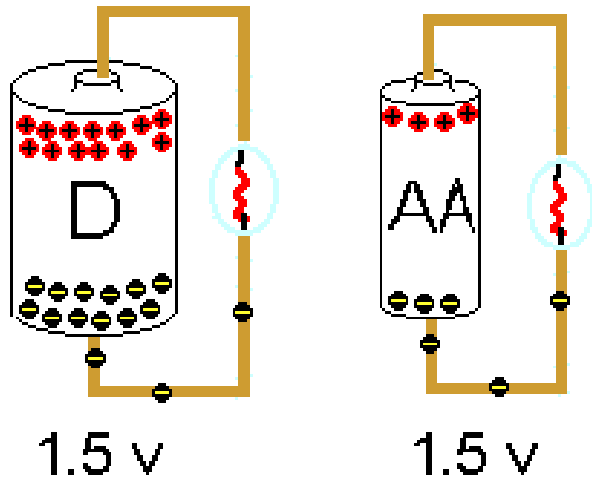

©1999 Science Joy Wagon

In a battery, a series of chemical reactions occur in which electrons are transferred from one terminal to another. There is a **potential difference (voltage)** between these poles.

The **maximum potential difference** a power source can have is called the **electromotive force or (EMF)**,  $\epsilon$ . The term isn't actually a force, simply the amount of energy per charge (J/C or V)

$$\text{Voltage} = \text{Potential Difference} = \text{Emf}$$
$$V = \Delta V = \epsilon$$

---

# A Basic Circuit

All electric circuits have three main parts

1. A source of energy
2. A closed path
3. A device which uses the energy

If ANY part of the circuit is open the device will not work!

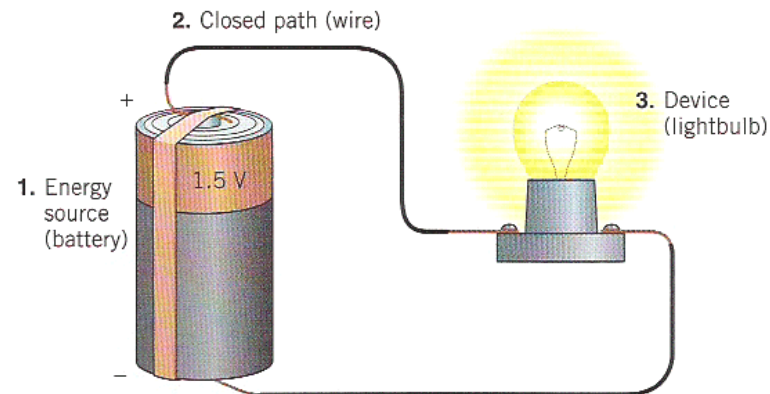

# Electricity can be symbolic of Fluids

Circuits are very similar to water flowing through a pipe

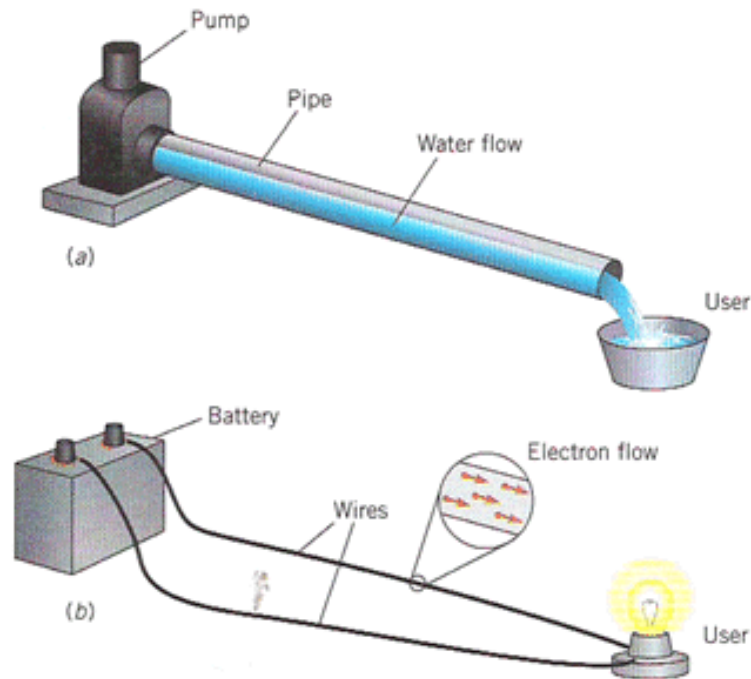

A pump basically works on TWO IMPORTANT PRINCIPLES concerning its flow

- There is a **PRESSURE DIFFERENCE** where the flow begins and ends
- A certain **AMOUNT** of flow passes each **SECOND**.

A circuit basically works on TWO IMPORTANT PRINCIPLES

- There is a "**POTENTIAL DIFFERENCE aka VOLTAGE**" from where the charge begins to where it ends
- The **AMOUNT of CHARGE** that flows **PER SECOND** is called **CURRENT**.

# Current

Current is defined as the rate at which charge flows through a surface.

$$I = \frac{q}{t} = \frac{dq}{dt} = \frac{\text{Coulombs}}{\text{seconds}} = \text{Ampere} = \text{Amp}$$

The current is in the same direction as the flow of **positive** charge (for this course)

**Note:** The “I” stands for *intensity*

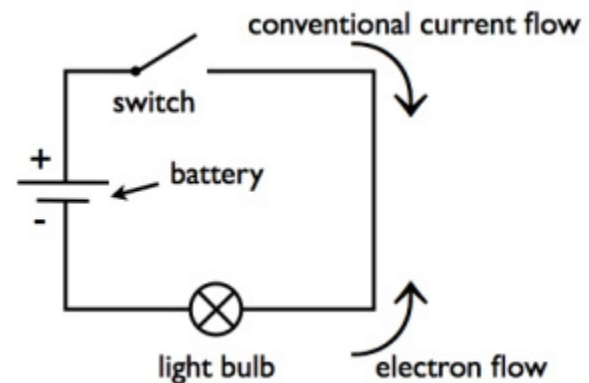

# There are 2 types of Current

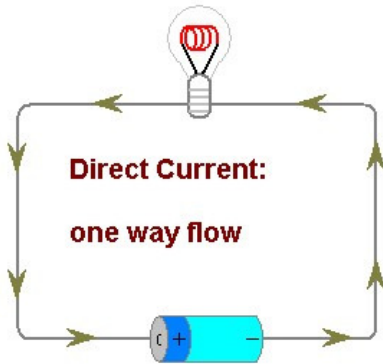

**DC = Direct Current** - current flows in one direction  
**Example:** Battery

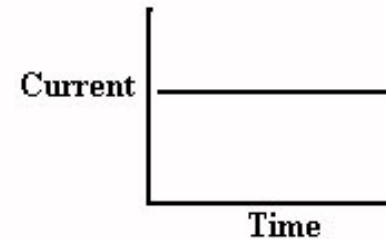

**AC = Alternating Current**- current reverses direction many times per second. This suggests that AC devices turn OFF and ON. **Example:** Wall outlet (progress energy)

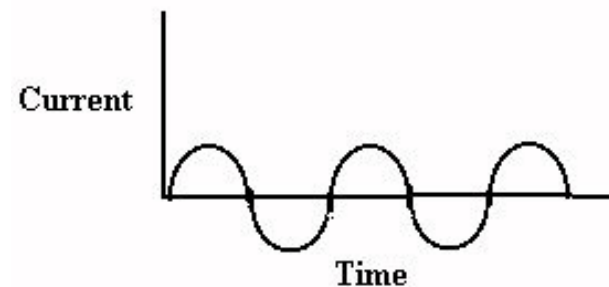
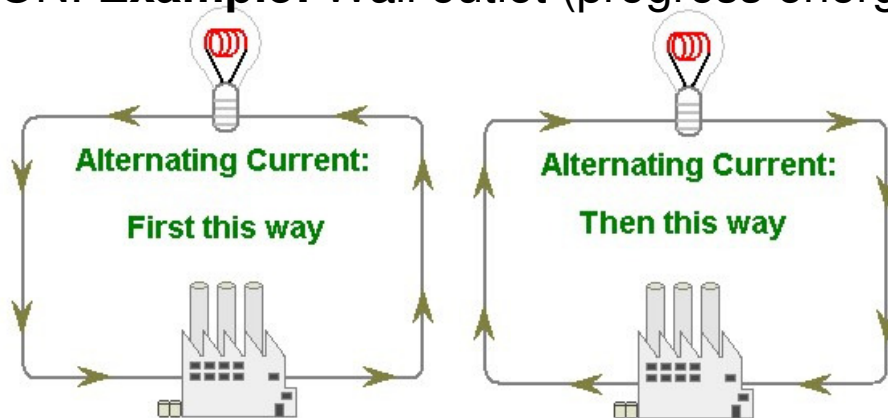

# Ohm's Law

*“The voltage (potential difference, emf) is directly related to the current, when the resistance is constant”*

$$\Delta V \propto I$$

$R =$  constant of proportionality

$R =$  Resistance

$$\Delta V = IR$$

$$\mathcal{E} = IR$$

Since  $R = \Delta V / I$ , the resistance is the **SLOPE** of a  $\Delta V$  vs.  $I$  graph

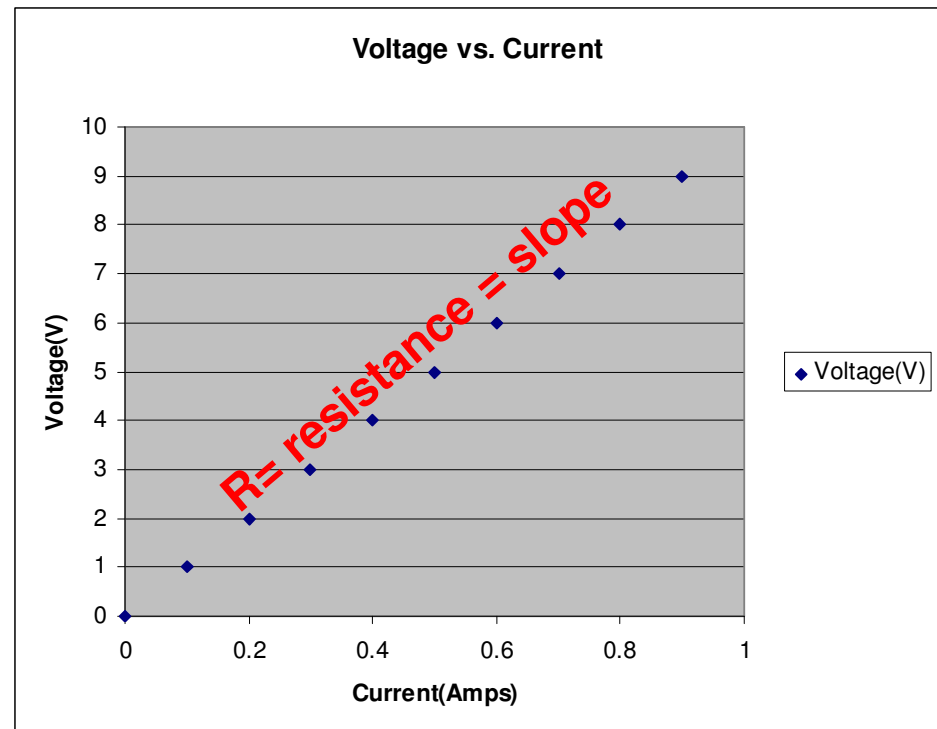

# Resistance

**Resistance (R)** – is defined as the restriction of electron flow. It is due to interactions that occur at the atomic scale. For example, as electrons move through a conductor they are attracted to the protons on the nucleus of the conductor itself. This attraction doesn't stop the electrons, just slow them down a bit and cause the system to waste energy.

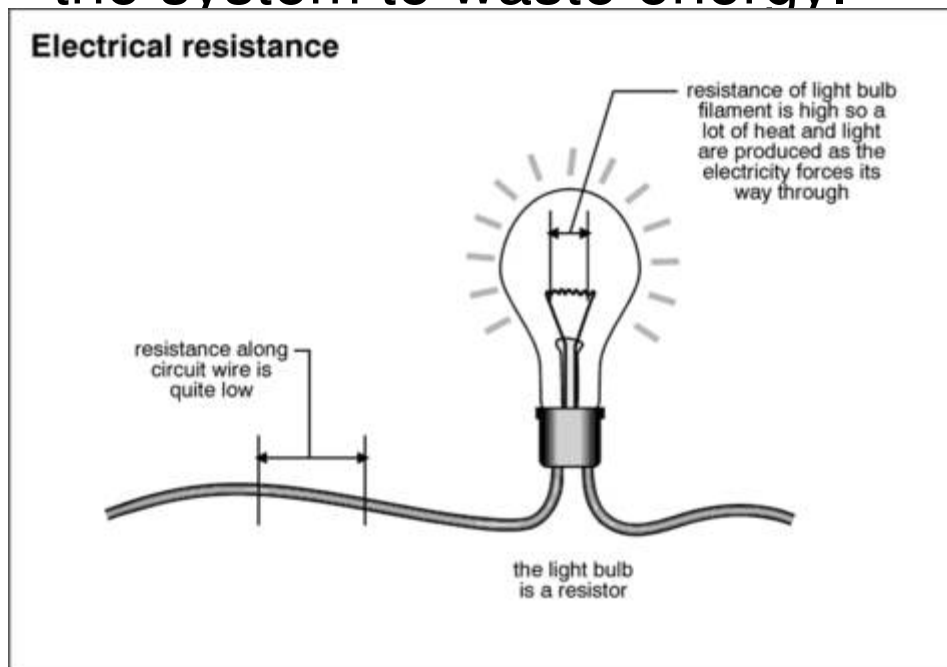

**The unit for resistance is the OHM,  $\Omega$**



# Electrical POWER

We have already learned that POWER is the rate at which work (energy) is done. Circuits that are a prime example of this as batteries only last for a certain amount of time AND we get charged an energy bill each month based on the amount of energy we used over the course of a month...aka POWER.

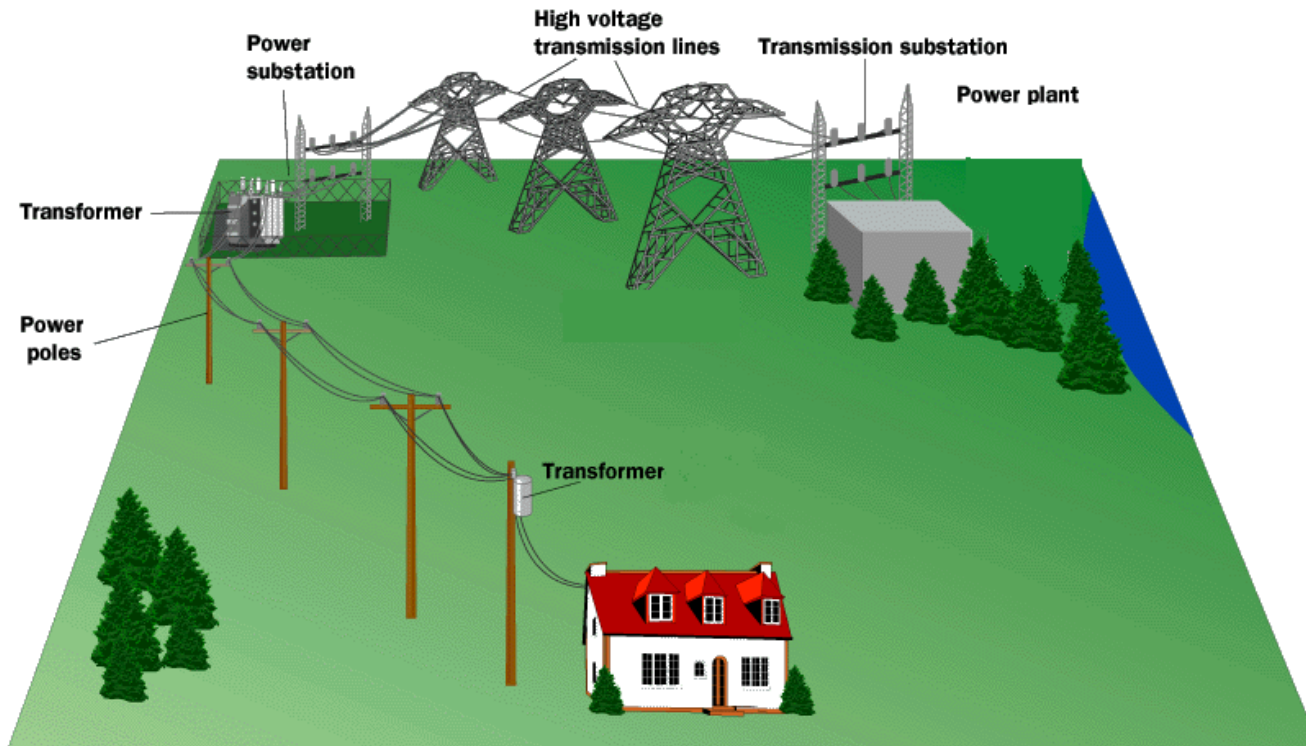

---

# POWER

It is interesting to see how certain electrical variables can be used to get POWER. Let's take Voltage and Current for example.

$$V = \frac{\text{Joules}}{\text{Coulomb}}$$

$$I = \frac{\text{Coulombs}}{\text{Second}}$$

$$V \times I = \frac{\text{Joules} \bullet \text{Coulombs}}{\text{Coulombs} \bullet \text{seconds}} = \frac{\text{Joules}}{\text{Second}} = \text{WATT!}$$

$$\text{Power} = P = VI$$

---

## Other useful power formulas

$$P = VI$$

$$V = IR$$

$$P = (IR)I = I^2 R$$

$$I = \frac{V}{R}$$

$$P = V\left(\frac{V}{R}\right) = \frac{V^2}{R}$$

These formulas can also be used! They are simply derivations of the POWER formula with different versions of Ohm's law substituted in.

---

# Ways to Wire Circuits

There are 2 basic ways to wire a circuit. Keep in mind that a resistor could be ANYTHING ( bulb, toaster, ceramic material...etc)

**Series** – One after another

**Parallel** – between a set of junctions and parallel to each other

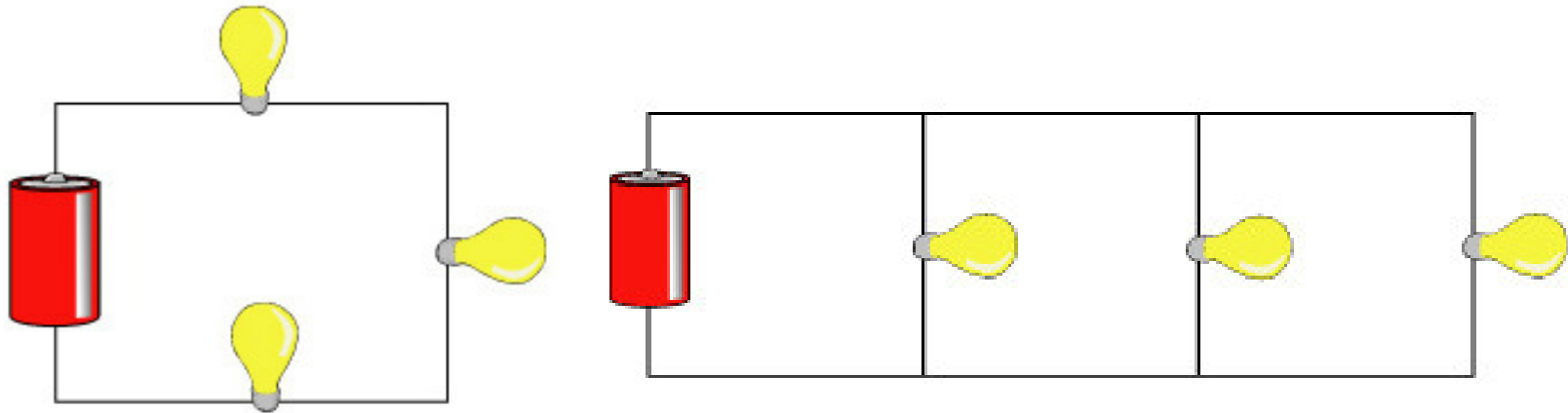

# Schematic Symbols

Before you begin to understand circuits you need to be able to draw what they look like using a set of standard symbols understood anywhere in the world

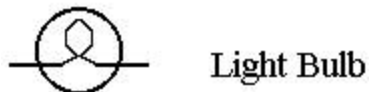
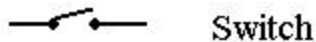
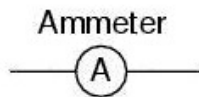
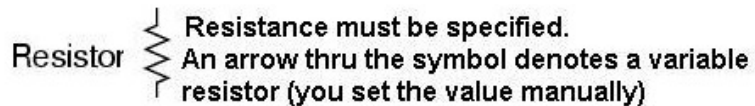
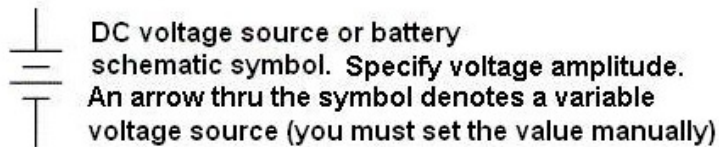

**For the battery symbol, the LONG line is considered to be the POSITIVE terminal and the SHORT line , NEGATIVE.**

**The VOLTMETER and AMMETER are special devices you place IN or AROUND the circuit to measure the VOLTAGE and CURRENT.**

# The Voltmeter and Ammeter



Voltmeter

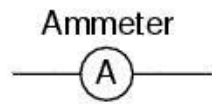

Ammeter

The voltmeter and ammeter cannot be just placed anywhere in the circuit. They must be used according to their DEFINITION.

Current goes **THROUGH** the ammeter

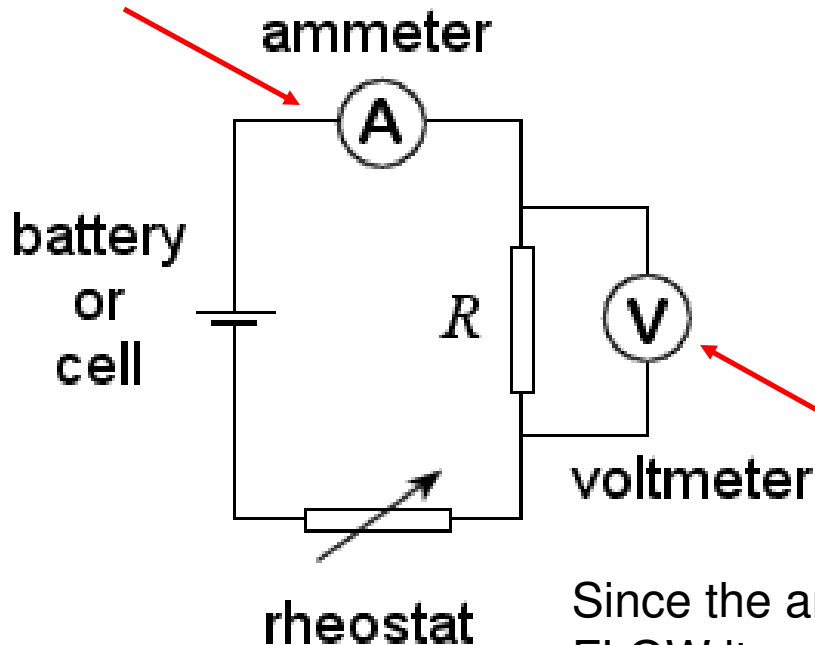

Since a voltmeter measures voltage or **POTENTIAL DIFFERENCE** it must be placed **ACROSS** the device you want to measure. That way you can measure the **CHANGE** on either side of the device.

Voltmeter is drawn **ACROSS** the resistor

Since the ammeter measures the current or **FLOW** it must be placed in such a way as the charges go **THROUGH** the device.

# Simple Circuit

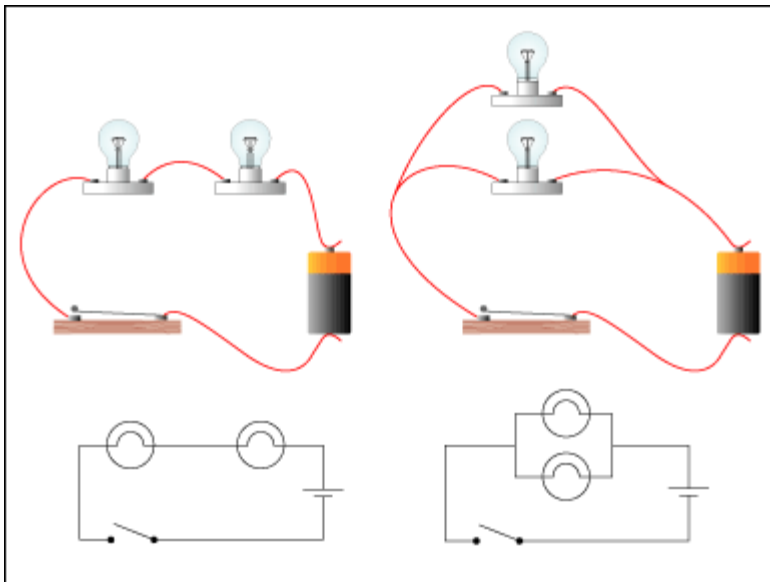
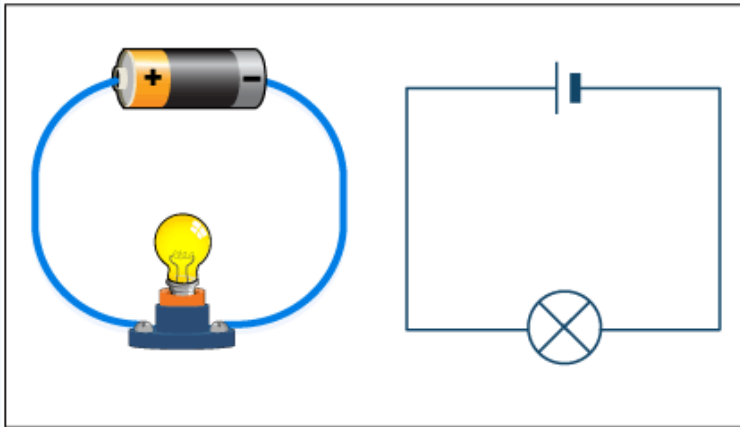

When you are drawing a circuit it may be a wise thing to start by drawing the battery first, then follow along the loop (closed) starting with positive and drawing what you see.

# Series Circuit

In a series circuit, the resistors are wired one after another. Since they are all part of the SAME LOOP they each experience the SAME AMOUNT of current. In figure, however, you see that they all exist BETWEEN the terminals of the battery, meaning they SHARE the potential (voltage).

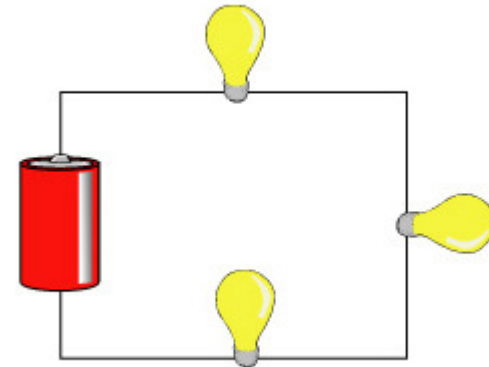

$$I_{(series)Total} = I_1 = I_2 = I_3$$

$$V_{(series)Total} = V_1 + V_2 + V_3$$



# Series Circuit

$$I_{(series)Total} = I_1 = I_2 = I_3$$

$$V_{(series)Total} = V_1 + V_2 + V_3$$

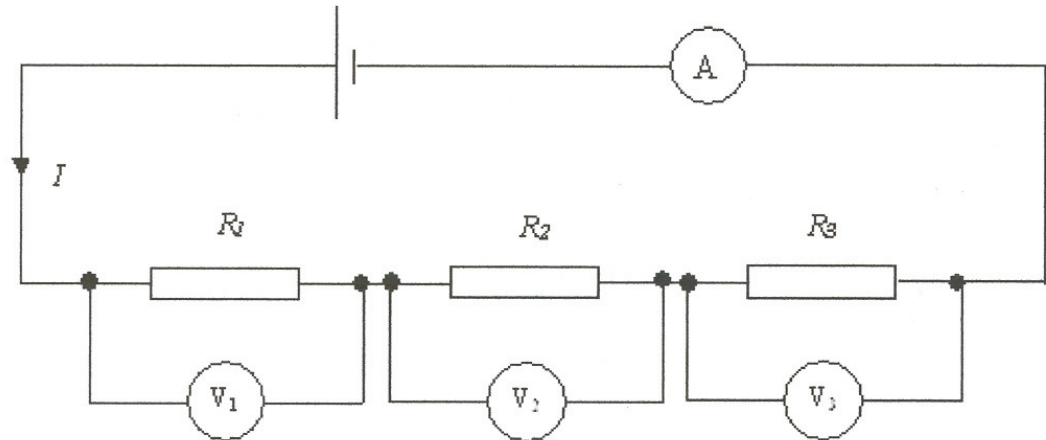

As the current goes through the circuit, the charges must **USE ENERGY** to get through the resistor. So each individual resistor will get its own individual potential (voltage). We call this **VOLTAGE DROP**.

$$V_{(series)Total} = V_1 + V_2 + V_3; \quad \Delta V = IR$$

$$(I_T R_T)_{series} = I_1 R_1 + I_2 R_2 + I_3 R_3$$

$$R_{series} = R_1 + R_2 + R_3$$

$$R_s = \sum R_i$$

**Note:** They may use the terms “effective” or “equivalent” to mean **TOTAL!**

# Example

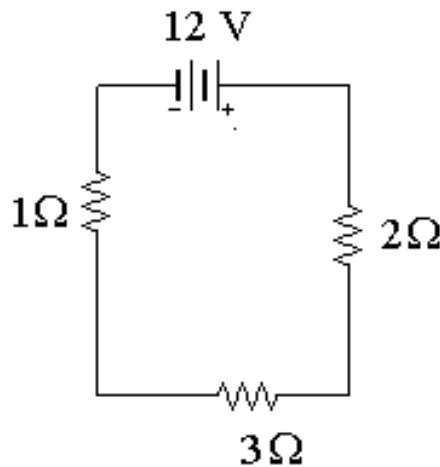

A series circuit is shown to the left.

a) What is the total resistance?

$$R(\text{series}) = 1 + 2 + 3 = 6\Omega$$

b) What is the total current?

$$\Delta V = IR \quad 12 = I(6) \quad I = 2A$$

c) What is the current across EACH resistor?

**They EACH get 2 amps!**

d) What is the voltage drop across each resistor? (Apply Ohm's law to each resistor separately)

$$V_{1\Omega} = (2)(1) = 2V$$

$$V_{3\Omega} = (2)(3) = 6V$$

$$V_{2\Omega} = (2)(2) = 4V$$

**Notice that the individual VOLTAGE DROPS add up to the TOTAL!!**

# Kirchhoff's Voltage Law

***“The sum of the potential changes around any closed loop is ZERO.”***

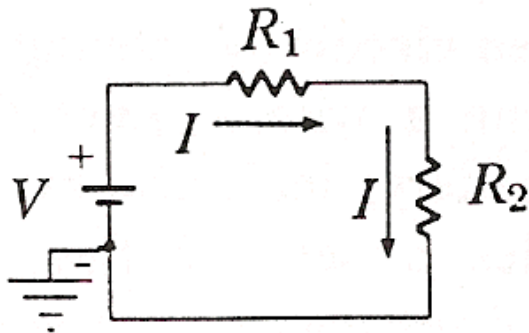

The rule is that as you move AWAY from the positive potential the potential is decreasing. So at ANY point if you find the change you get a negative number. As you move towards the positive potential the potential increases thus the change is positive.

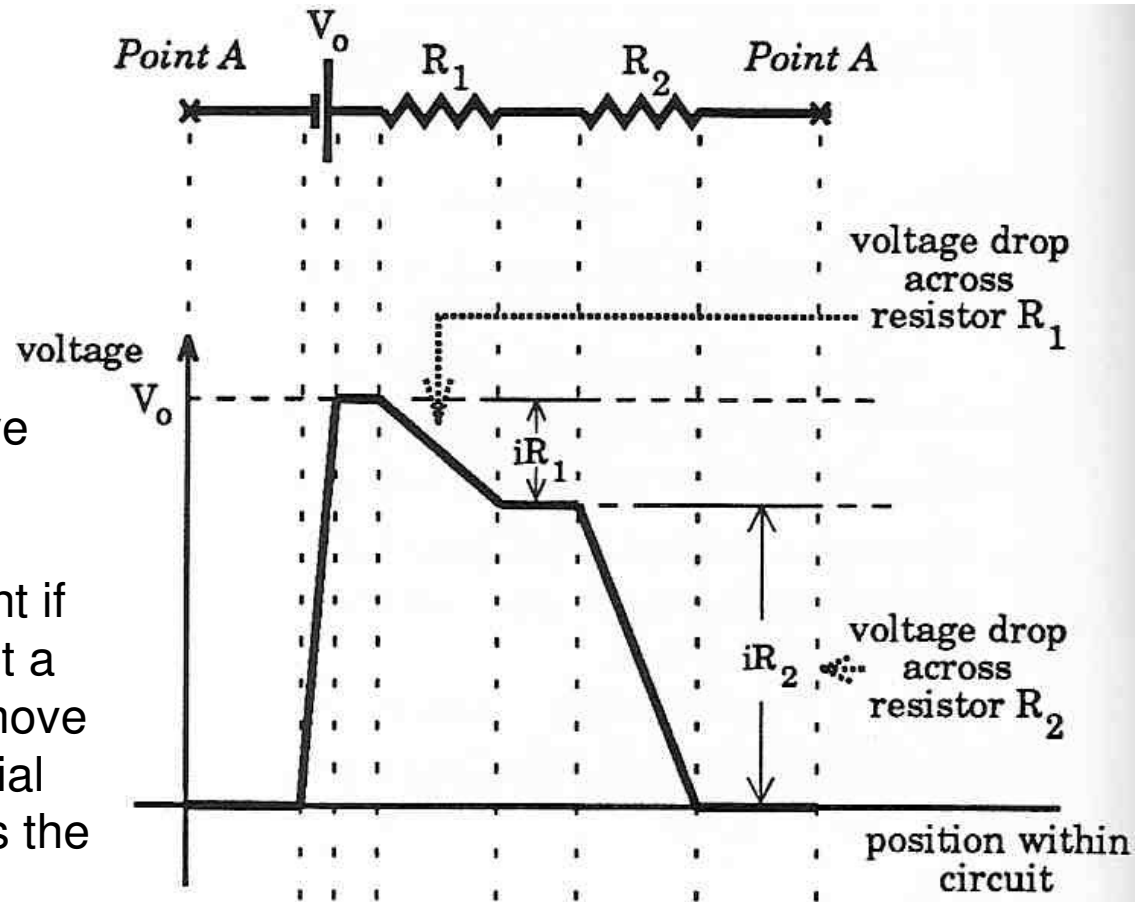

# Kirchhoff's Voltage Law – Series Circuit

$$V_{Total} + (-IR_1) + (-IR_2) = 0$$

$$V_{Total} = IR_1 + IR_2, \quad V_{Total} = IR_{Total}$$

$$IR_{Total} = IR_1 + IR_2 \quad (\text{"I" Cancels})$$

$$R_{Total} = R_1 + R_2 \rightarrow R_{Total(series)} = \sum_i^n R_i$$

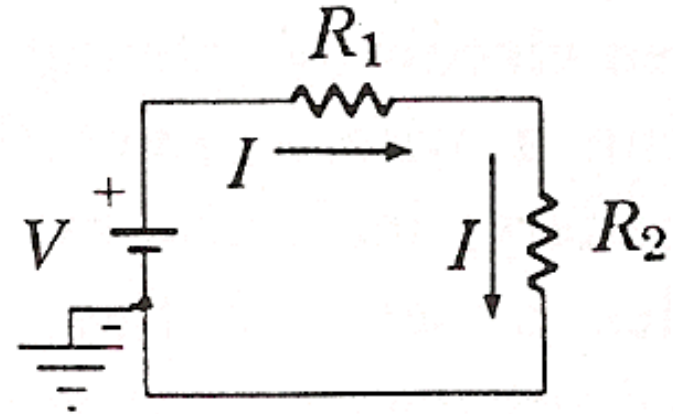

Here we see that applying Kirchhoff's Voltage Law to this loop produces the formula for the **effective** resistance in a series circuit. The word **effective** or **equivalent** means the same thing as the TOTAL.

# Parallel Circuit

In a parallel circuit, we have multiple loops. So the current splits up among the loops with the individual loop currents **adding** to the total current

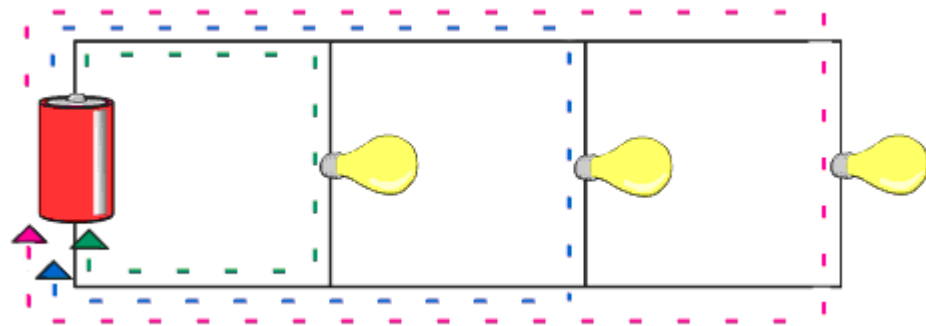
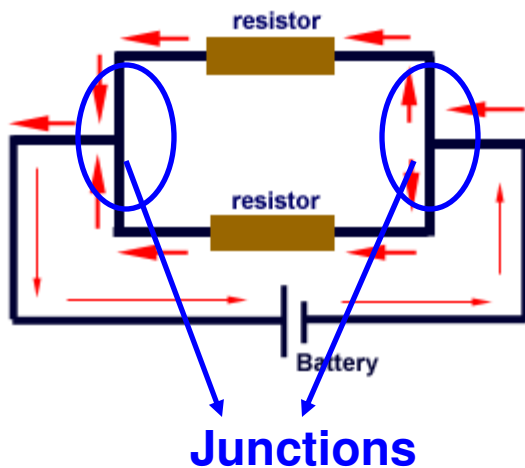

It is important to understand that parallel circuits will all have some position where the current splits and comes back together. We call these **JUNCTIONS**.

The current going IN to a junction will always equal the current going OUT of a junction.

$$I_{(parallel)Total} = I_1 + I_2 + I_3$$

Regarding Junctions :

$$I_{IN} = I_{OUT}$$

# Parallel Circuit

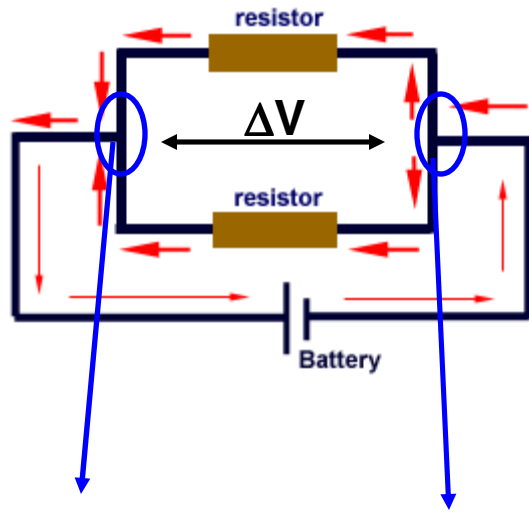

This junction touches the **POSITIVE** terminal

This junction touches the **NEGATIVE** terminal

Notice that the JUNCTIONS both touch the POSTIVE and NEGATIVE terminals of the battery. That means you have the SAME potential difference down EACH individual branch of the parallel circuit. This means that the individual voltages drops are equal.

$$V_{(parallel)Total} = V_1 = V_2 = V_3$$

$$I_{(parallel)Total} = I_1 + I_2 + I_3; \Delta V = IR$$

$$\left(\frac{V_T}{R_T}\right)_{Parallel} = \frac{V_1}{R_1} + \frac{V_2}{R_2} + \frac{V_3}{R_3}$$

$$\frac{1}{R_P} = \frac{1}{R_1} + \frac{1}{R_2} + \frac{1}{R_3}$$

$$\frac{1}{R_P} = \sum \frac{1}{R_i}$$

# Example

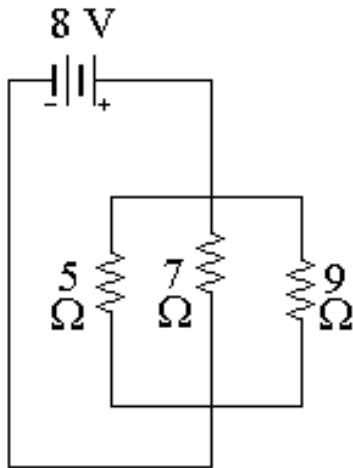

To the left is an example of a parallel circuit.

a) What is the total resistance?

$$\frac{1}{R_p} = \frac{1}{5} + \frac{1}{7} + \frac{1}{9}$$

$$\frac{1}{R_p} = 0.454 \rightarrow R_p = \frac{1}{0.454} = \mathbf{2.20 \Omega}$$

b) What is the total current?  $\Delta V = IR$

$$8 = I(R) = \mathbf{3.64 A}$$

c) What is the voltage across EACH resistor?

**8 V each!**

d) What is the current drop across each resistor?  
(Apply Ohm's law to each resistor separately)

$$\Delta V = IR$$

$$I_{5\Omega} = \frac{8}{5} = \mathbf{1.6 A} \quad I_{7\Omega} = \frac{8}{7} = \mathbf{1.14 A} \quad I_{9\Omega} = \frac{8}{9} = \mathbf{0.90 A}$$

Notice that the individual currents **ADD** to the total.

# Kirchhoff's Current Law

***“The sum of the currents flowing into a junction is equal to the sum of the currents flowing out.”***

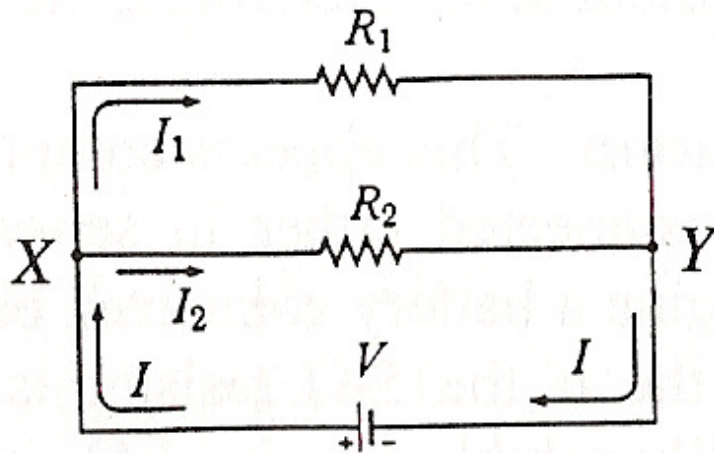

When two resistors have BOTH ends connected together, with nothing intervening, they are connected in PARALLEL. The drop in potential when you go from X to Y is the SAME no matter which way you go through the circuit. Thus resistors in parallel have the same potential drop.

$$I_{Total} = I_1 + I_2$$

$$\frac{V_T}{R_T} = \frac{V_1}{R_1} + \frac{V_2}{R_2}$$

$$\frac{1}{R_T} = \frac{1}{R_1} + \frac{1}{R_2}$$

$$\frac{1}{R_p} = \sum_i^n \frac{1}{R_i}$$



# Applying Kirchhoff's Laws

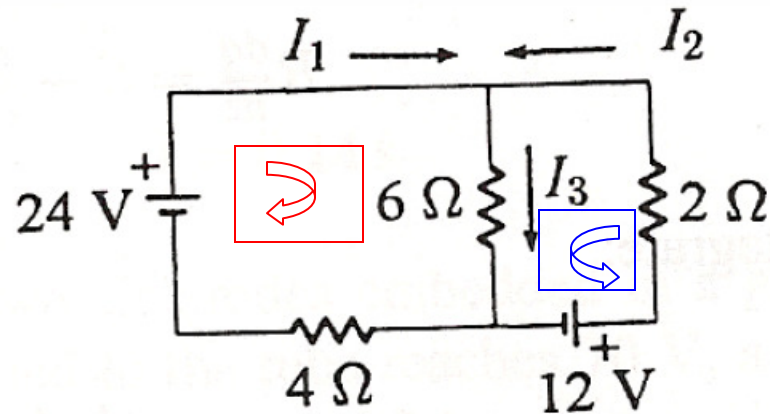

**Goal:** Find the three unknown currents.

First decide which way you think the current is traveling around the loop. It is OK to be incorrect.

$$\text{Red Loop} \rightarrow V + (-I_3 6) + (-I_1 4) = 0$$

$$24 = 6I_3 + 4I_1$$

Using Kirchhoff's Voltage Law

$$\text{Blue Loop} \rightarrow V + (-I_2 2) + (-I_3 6) = 0$$

$$12 = 2I_2 + 6I_3$$

Using Kirchhoff's Current Law

$$I_1 + I_2 = I_3$$

# Applying Kirchhoff's Laws

$$24 = 6I_3 + 4I_1$$

$$12 = 2I_2 + 6I_3$$

$$I_3 = I_1 + I_2$$

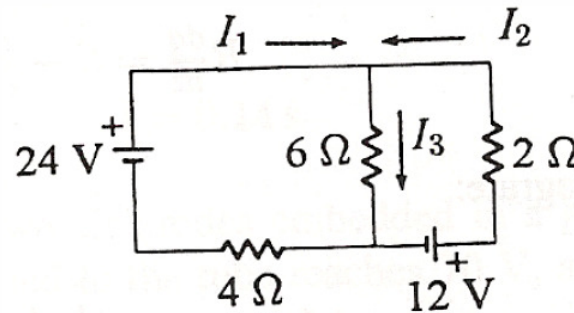

$$24 = 6(I_1 + I_2) + 4I_1 = 6I_1 + 6I_2 + 4I_1 = 10I_1 + 6I_2$$

$$12 = 2I_2 + 6(I_1 + I_2) = 2I_2 + 6I_1 + 6I_2 = 6I_1 + 8I_2$$

$$24 = 10I_1 + 6I_2 \rightarrow -6(24 = 10I_1 + 6I_2)$$

$$12 = 6I_1 + 8I_2 \rightarrow 10(12 = 6I_1 + 8I_2)$$

$$-144 = -60I_1 - 36I_2 \quad 120 = 60I_1 + 80I_2$$

$$-24 = 44I_2$$

$$I_2 = -0.545 \text{ A}$$

A NEGATIVE current does NOT mean you are wrong. It means you chose your current to be in the wrong direction initially.

# Applying Kirchhoff's Laws

$$12 = 2I_2 + 6I_3 \rightarrow 12 = 2(-0.545) + 6I_3$$

$$I_3 = \mathbf{2.18 \text{ A}}$$

$$24 = 6I_3 + 4I_1 \rightarrow 24 = 6(?) + 4I_1$$

$$I_1 = \mathbf{2.73 \text{ A}}$$

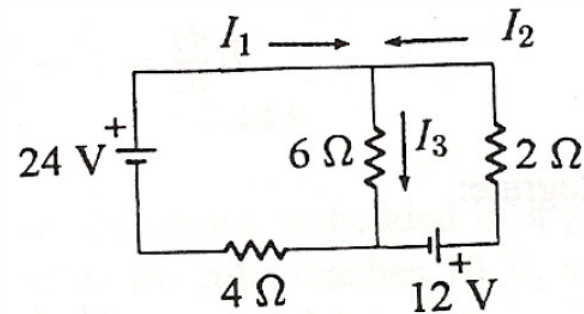

Instead of :  $I_3 = I_1 + I_2$

It should have been :  $I_1 = I_2 + I_3$

$$2.73 = 2.18 + 0.545$$

# Compound (Complex) Circuits

Many times you will have series and parallel in the SAME circuit.

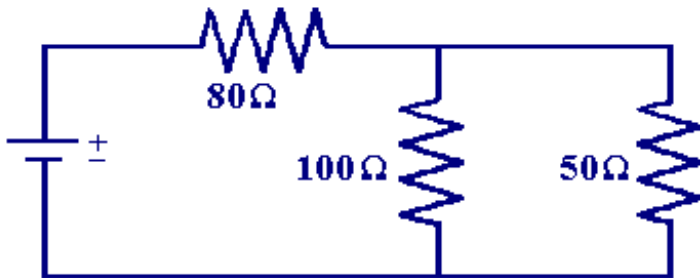

Solve this type of circuit from the inside out.

**WHAT IS THE TOTAL RESISTANCE?**

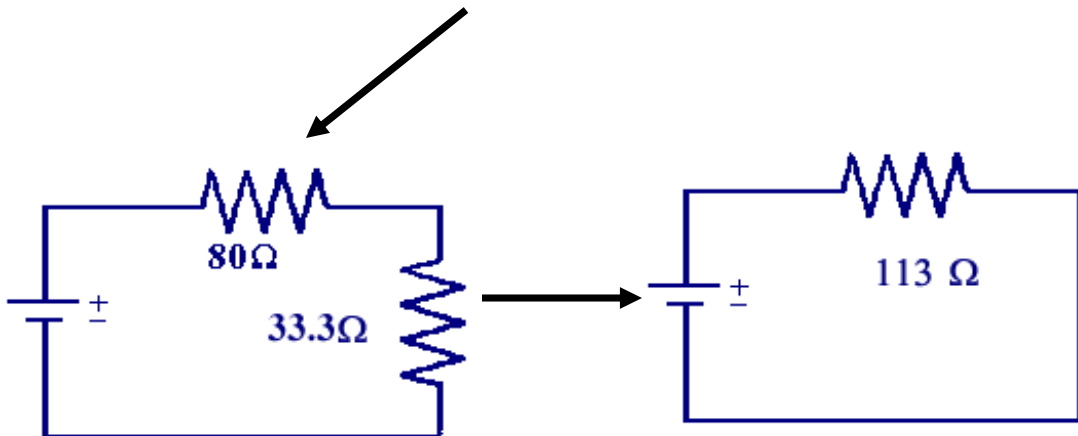

$$\frac{1}{R_p} = \frac{1}{100} + \frac{1}{50}; \quad R_p = 33.3\ \Omega$$
$$R_s = 80 + 33.3 = 113.3\ \Omega$$

# Compound (Complex) Circuits

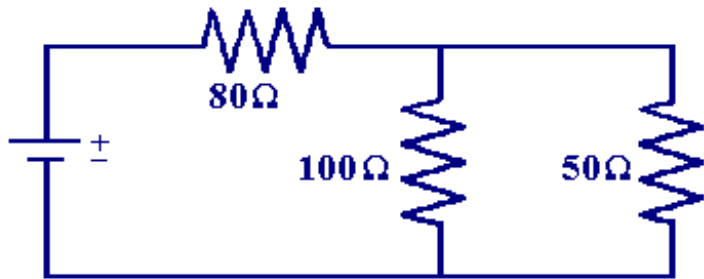

$$\frac{1}{R_p} = \frac{1}{100} + \frac{1}{50}; \quad R_p = 33.3\Omega$$

$$R_s = 80 + 33.3 = 113.3\Omega$$

Suppose the potential difference (voltage) is equal to **120V**. What is the total current?

$$\Delta V_T = I_T R_T$$

$$120 = I_T (113.3)$$

$$I_T = \mathbf{1.06 \text{ A}}$$

$$\Delta V_{80\Omega} = I_{80\Omega} R_{80\Omega}$$

$$V_{80\Omega} = (1.06)(80)$$

$$V_{80\Omega} = \mathbf{84.8 \text{ V}}$$

What is the VOLTAGE DROP across the 80Ω resistor?

# Compound (Complex) Circuits

$$R_T = 113.3\Omega$$

$$V_T = 120V$$

$$I_T = 1.06A$$

$$V_{80\Omega} = 84.8V$$

$$I_{80\Omega} = 1.06A$$

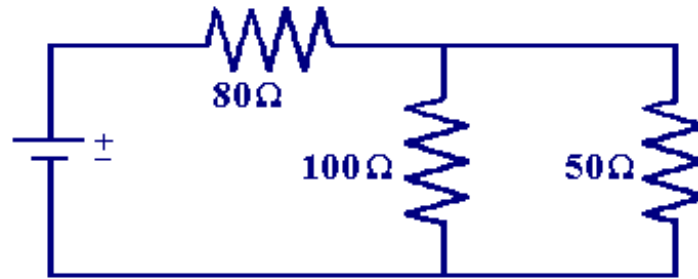

What is the current across the 100Ω and 50Ω resistor?

What is the VOLTAGE DROP across the 100Ω and 50Ω resistor?

$$V_{T(\text{parallel})} = V_2 = V_3$$

$$V_{T(\text{series})} = V_1 + V_{2\&3}$$

$$120 = 84.8 + V_{2\&3}$$

$$V_{2\&3} = \mathbf{35.2\ V\ Each!}$$

$$I_{T(\text{parallel})} = I_2 + I_3$$

$$I_{T(\text{series})} = I_1 = I_{2\&3}$$

$$I_{100\Omega} = \frac{35.2}{100} = \mathbf{0.352\ A}$$

$$I_{50\Omega} = \frac{35.2}{50} = \mathbf{0.704\ A}$$

**Add to  
1.06A**